

E

Micro-Nikkor

200mm

f/4 IF

Nikon INSTRUCTION MANUAL



NOMENCLATURE

Aperture scale index dot

Meter coupling shoe

Meter coupling ridge

Aperture indexing post for Nikon SB-E Speedlight

EE servo coupling post

Aperture-direct-readout scale

Aperture ring

Aperture scale

Tripod mounting collar

Tripod collar alignment index dots

Depth-of-field indicators

Reproduction ratio scale

Focusing ring

Distance scale

Distance scale index line

Tripod collar locking screw

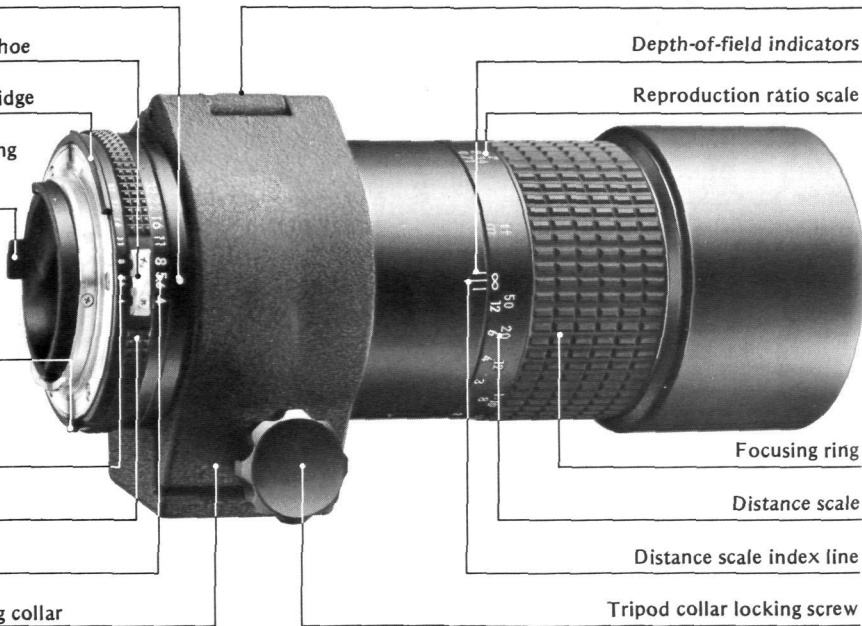

CONTENTS

NOMENCLATURE	2
FOREWORD	4
MOUNTING THE LENS	5
FOCUSING	6 – 9
Recommended Focusing Screens	7
Focusing at a Predetermined Ratio	8
Reproduction Ratio	8
Depth of Field	9
NOTES ON FOCUSING	9
DETERMINING EXPOSURE	10 – 11
With Built-In TTL Metering	10
Without TTL Metering	11
CLOSE-UP TABLES	12
DEPTH-OF-FIELD TABLES	13 – 14
FEATURES/SPECIFICATIONS	15

FOREWORD

Representing a true breakthrough in lens design, the Micro-Nikkor 200mm f/4 IF is the world's first 200mm "micro" lens. By utilizing internal focusing (IF), a system in which the lens elements move inside the lens, there is absolutely no increase in the overall length of the lens barrel as the lens is focused closer. Therefore, it is extremely easy to handle. At its closest focusing distance of 0.71m (2.34 ft.), the lens produces a 1:2 reproduction ratio. When the Nikon TC-301 Teleconverter is used, full life-size images (1:1) are possible (with a decrease in the effective aperture to f/8). This lens is very light-weight and has its own built-in telescoping lens hood and detachable tripod mounting collar.

Because of its 200mm focal length, this lens offers tremendous free-working distance, so that you can take close-up shots of shy or dangerous subjects, like butterflies or poisonous snakes, and still keep your distance. Even at 1:2 magnification, the free-working distance is approximately 50cm (19.5 in.) between the front of the lens and the subject. It also focuses to infinity, making it perfect for use as a regular 200mm telephoto lens. In addition, NIC (Nikon Integrated Coating) is applied to the air-to-glass surfaces of lens elements to reduce ghost images and flare and improve contrast.

MOUNTING THE LENS



Position the lens in the camera's bayonet mount, aligning the aperture scale index dot on the lens with the lens mounting index on the camera body. Twist the lens counter-clockwise until it clicks into place. To remove, depress the lens release button on the camera and twist the lens clockwise.

Note: When mounting the lens on a camera with a meter coupling lever (AI type), make sure that the camera's meter coupling lever is correctly positioned; when mounting on a camera without this lever (non-AI type), "manual" maximum aperture indexing is required. In both cases, refer to the camera's instruction manual.

FOCUSING



The fully automatic diaphragm of the Micro-Nikkor enables focusing with maximum image brightness throughout the entire focusing range of the lens. As the image is constantly viewed at the *maximum aperture setting* (i.e., $f/4$), the depth of field is minimized so that the image snaps in and out of focus rapidly and distinctly.

To focus, turn the focusing ring until the image on the *focusing screen* appears sharp and crisp. Via the special focusing helicoid, the Micro-Nikkor operates continuously from infinity (∞) to 0.71m (2.34 ft) for a reproduction ratio of 1:2.

The distance scale on the focusing ring is marked in both meters (white) and feet (yellow). These figures indicate the distance from the subject to the camera's film plane.

Recommended Focusing Screens

Various interchangeable focusing screens are available for Nikon F3- and F2-series cameras to suit any type of lens or picture-taking situation. Those which are recommended for use with this lens are listed below. For screens used with Nikon cameras other than F3- and F2-series cameras (e.g., Nikon FA, FE2, FM2 and FE), refer to the columns for F3-series cameras. For the K2, B2 and E2 focusing screens, refer to the columns on the K, B and E screens, respectively. For details, also refer to the specific focusing screen's instruction sheet.

Camera	Screen	A/L	B	C	D	E	G1	G2	G3	G4	H1	H2	H3	H4	J	K/P	M	R	T	U
F 3		○	○	○	○	○			○				○	○	○	○	○	○	○	○
F 2		○	○	○	○	○			(-1)				(-1/2)	(-1)	○	○	○	○		

■ When the Teleconverter TC-301 or TC-300 is attached to this lens, use the following table:

Camera	Screen	A/L	B	C	D	E	G1	G2	G3	G4	H1	H2	H3	H4	J	K/P	M	R	T	U
F 3		●	○	○	○	○								○	●	●	●	●	○	○
F 2		●	○	○	○	○								○	●	●	●			

■ When the Teleconverter TC-14A is attached to this lens, use the following table*:

Camera	Screen	A/L	B	C	D	E	G1	G2	G3	G4	H1	H2	H3	H4	J	K/P	M	R	T	U
F 3		●	○			○									○	●			○	●
F 2		●	○			○									○	●			○	○

* Slight vignetting may occur.

■ When the Teleconverter TC-14B or TC-14 is attached to this lens, use the following table:

Camera	Screen	A/L	B	C	D	E	G1	G2	G3	G4	H1	H2	H3	H4	J	K/P	M	R	T	U
F 3		●	○	○	○	○			○				○		○	●			○	●
F 2		●	○	○	○	○			(-2)				(-1)		○	●			○	○

○ = Excellent focusing

● = Acceptable focusing

The split-image rangefinder, microprism or cross-hair area is dim. Focus on the surrounding matte area.

○ = Acceptable focusing

Slight vignetting (or moire phenomenon, in the case of the microprism) affects the screen image. The image on the film, however, shows no trace of this.

(-) = Indicates degree of exposure compensation.

Blank means inapplicable.

FOCUSING — continued

Focusing at a Predetermined Ratio

Above the distance scales on the focusing ring is the reproduction ratio scale inscribed in orange. The scale, with figures from 1:10 to 1:2, represents the reproduction ratios obtained when the lens is used alone.

Using this scale, you can photograph at a predetermined ratio without calculating the distances required. To photograph at a reproduction ratio of 1:5, for example, just turn the focusing ring until the orange-colored number "5" is aligned with the distance scale index; then aim at the subject and adjust your position (close to, or farther away from, the subject) until the image appears sharp and crisp on the focusing screen.

When the Nikon Teleconverter TC-301 is attached, the reproduction ratio increases to 1:1 and the automatic diaphragm still functions as before.

Reproduction Ratio

The reproduction ratio is the numerical expression of the relationship between the image size and the actual size of the subject. For example, if the image on the focusing screen is one-fifth the actual size of the subject, the reproduction ratio is said to be 1:5, and is indicated on the reproduction ratio scale of the Micro-Nikkor 200mm f/4 by the number "5."

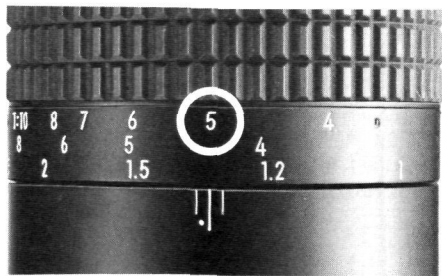

Depth of Field

Depth of field refers to the zone of acceptable focus extending in front of and behind the plane of sharpest focus. As this zone is exceptionally shallow at high reproduction ratios, previewing is desirable before shooting. To preview, press the depth-of-field button on the camera and the lens will close to the preselected aperture to allow you to see how much background and foreground is in focus. Depth of field can also be observed by reading the color-coded indicators inscribed on the lens barrel. A pair of orange lines on either side of the white distance scale index line corresponds to $f/32$ which is the same color on the aperture scale. At close distance, so little is in focus that the depth-of-field tables on pages 13 ~ 14 are more useful.

To avoid camera shake, close-up photography poses several problems not encountered in general photography. One of these is sensitivity to vibration: the magnification of the image on the film makes even slight image displacement prominent and results in a blurred image. Therefore, for best results, mount the camera on a tripod or on rigid supports, and use a cable release to trip the shutter.

At extremely close working distances, depth of field decreases to the actual focused distance. This can be partially compensated for by stopping down the lens. But at very close distances an extremely narrow depth of field is inevitable. Careful placement of the subject, if it has depth, will be necessary to ensure that the important surfaces will be in the same zone of sharpness.

DETERMINING EXPOSURE

Camera	Accessories	Exposure measurement
AI	TC-301	Full-aperture
AI	Bellows	Stop-down
non-AI	TC-301	Stop-down
non-AI	Bellows	Stop-down

With Built-In TTL Metering

The Micro-Nikkor has an automatic diaphragm with settings from $f/4$ to $f/32$ and couples to the thru-the-lens meter of the Nikon F3, any Nikon F2 Photomic or other Nikon/Nikkormat cameras for full-aperture exposure measurement over the entire range of aperture settings. Note that when this lens is used with non-AI cameras, "manual" maximum aperture indexing is required. When a teleconverter or bellows attachment is used, the exposure measurement method is as shown in the table on the left.

See the instruction manual supplied with your camera for details.

Caution:

- 1) When the full-aperture method is used at smaller apertures than the lens maximum aperture of $f/4$ with the lens set at the closest focus distance, make approx. $-1/2$ EV exposure compensation to prevent overexposure.
- 2) When the stop-down method is used at small apertures, use a finder eyecup to ensure complete exclusion of stray light.

Without TTL Metering

At close ranges (reproduction ratios greater than 1:10), the amount of light reaching the film decreases as the extension between the lens and film plane increases. When non-TTL measurement is used for this range, the result is underexposed photographs unless compensation has been made for this decrease. The table at the right gives the exposure factors (compensation values) with exposure increase in f/stop for non-TTL measurement at reproduction ratios greater than 1:10. The table at the right is for use when various extension equipment is attached*.

To calculate the necessary correction in shutter speed rather than in aperture value, multiply a given exposure factor by the exposure time. For instance, if the normal exposure at a 1:4 reproduction ratio is 1/8 second, the correct shutter speed is $1/8 \times 2 = 1/4$ second.

Reproduction ratio	Exposure factor	Exposure increase in f/stops
1/10	1.4	1/2
1/8	1.5	1/2
1/7	1.5	2/3
1/6	1.6	2/3
1/5	1.8	1
1/4	2.0	1
1/3	2.5	1-1/3
1/2	3.4	1-2/3
1/1.8	3.8	2
1/1.6	4.3	2
1/1.4	4.9	2-1/3
1/1.2	5.8	2-1/2
1/1	7.3	3
1.2	9.2	3-1/3
1.4	11.4	3-1/2
1.6	13.8	3-2/3
1.8	16.5	4
2	19.4	4-1/3

*When you use the lens by itself or attach a teleconverter, such as the TC-301, exposure compensation is not necessary.

CLOSE-UP TABLES

(cm)

Close-up attachment	Lens in normal position			Lens in reverse position		
	Reproduction ratio	Subject field	Focused distance	Reproduction ratio	Subject field	Focused distance
Close-Up Lens No. 0	1/7.1-1/1.5	16.9 x 25.4-3.6 x 5.4	164-58.7	—	—	—
Close-Up Lens No. 1	1/3.4-1/1.2	8.1 x 12.1-2.8 x 4.2	90.4-51.1	—	—	—
Close-Up Lens No. 2	1/1.7-1.2	4.1 x 6.1-2.0 x 3.0	56.7-42.8	—	—	—
E2 Ring	1/14-1/1.7	34.3 x 51.4-4.0 x 6.1	325-67.8	—	—	—
* K Ring Set	1/35-1/1.2	82.8 x 124-3.0 x 4.4	728-64.3	—	—	—
** PK-Series Ring(s)	1/25-1/1.2	60.0 x 90.0-2.9 x 4.3	538-64.2	—	—	—
PN-Series Ring	1/3.8-1/1.2	9.1 x 13.7-2.8 x 4.2	119-64.0	—	—	—
*** Bellows PB-4, PB-5	1/4.7-1/1.1	11.2 x 16.7-2.6 x 3.9	135-77.7	1/∞-1/2.5	∞ x ∞-6.1 x 9.1	∞-96.1
Bellows PB-6	1/4.2-1.0	10.0 x 15.0-2.3 x 3.5	126-77.6	—	—	—
Extension Bellows PB-6E	1/4.2-2.2	10.0 x 15.0-1.1 x 1.6	126-90.5	1/∞-1/1.3	∞ x ∞-3.1 x 4.6	∞-78.8
**** Reprocopy Outfit PF-2, PF-3, PF-4	1/1.9-1/2	4.4 x 6.7-4.8 x 7.2	85.3-71.0	—	—	—

(inch)

Close-up attachment	Lens in normal position			Lens in reverse position		
	Reproduction ratio	Subject field	Focused distance	Reproduction ratio	Subject field	Focused distance
Close-Up Lens No. 0	1/7.1-1/1.5	6.7 x 10.0-1.4 x 2.1	64.5-23.1	—	—	—
Close-Up Lens No. 1	1/3.4-1/1.2	3.2 x 4.8-1.1 x 1.7	35.6-20.1	—	—	—
Close-Up Lens No. 2	1/1.7-1.2	1.6 x 2.4-0.78 x 1.2	22.3-16.8	—	—	—
E2 Ring	1/14-1/1.7	13.5 x 20.2-1.6 x 2.4	128-26.7	—	—	—
* K Ring Set	1/35-1/1.2	32.6 x 48.9-1.2 x 1.7	287-25.3	—	—	—
** PK-Series Ring(s)	1/25-1/1.2	23.6 x 35.4-1.1 x 1.7	212-25.3	—	—	—
PN-Series Ring	1/3.8-1/1.2	3.6 x 5.4-1.1 x 1.7	46.8-25.2	—	—	—
*** Bellows PB-4, PB-5	1/4.7-1/1.1	4.4 x 6.6-1.0 x 1.5	53.1-30.6	1/∞-1/2.5	∞ x ∞-2.4 x 3.6	∞-37.8
Bellows PB-6	1/4.2-1.0	3.9 x 5.9-0.91 x 1.4	49.5-30.5	—	—	—
Extension Bellows PB-6E	1/4.2-2.2	3.9 x 5.9-0.43 x 0.65	49.5-35.6	1/∞-1/1.3	∞ x ∞-1.2 x 1.8	∞-31.0
**** Reprocopy Outfit PF-2, PF-3, PF-4	1/1.9-1/2	1.7 x 2.6-1.9 x 2.8	33.6-28.0	—	—	—

- * The first values are for the K1 ring used alone and the second ones for all five rings used together.
- ** The first values are for the PK-1 or PK-11/PK-11A ring used alone and the second ones for three rings (PK-1 ~ PK-3 or PK-11/PK-11A ~ PK-13) used together.
- *** The reproduction ratio range of the PB-4 and PB-5 with the lens mounted in the reverse position is obtained when the BR-2 Ring is used in combination with the bellows unit.
- **** The figures shown here represent the ranges obtained with the subject on the baseplate, using the lens without any close-up attachment.

DEPTH-OF-FIELD TABLES

(m)

Focused distance	Depth of field							Reproduction ratio
	f/4	f/5.6	f/8	f/11	f/16	f/22	f/32	
0.71	0.709–0.711	0.709–0.711	0.709–0.711	0.708–0.712	0.707–0.713	0.706–0.714	0.705–0.715	1/1.99
0.80	0.799–0.801	0.799–0.801	0.798–0.802	0.797–0.803	0.796–0.804	0.795–0.805	0.792–0.808	1/2.44
0.90	0.899–0.901	0.898–0.902	0.897–0.903	0.896–0.904	0.895–0.905	0.893–0.908	0.889–0.911	1/2.94
1.0	0.998–1.00	0.997–1.00	0.996–1.00	0.995–1.01	0.993–1.01	0.990–1.01	0.986–1.01	1/3.4
1.2	1.20–1.20	1.20–1.20	1.19–1.21	1.19–1.21	1.19–1.21	1.18–1.22	1.18–1.22	1/4.4
1.5	1.49–1.51	1.49–1.51	1.49–1.51	1.49–1.51	1.48–1.52	1.47–1.53	1.46–1.54	1/5.9
2.0	1.99–2.01	1.99–2.01	1.98–2.02	1.97–2.03	1.96–2.04	1.95–2.06	1.92–2.08	1/8.4
3.0	2.98–3.03	2.97–3.04	2.95–3.05	2.93–3.07	2.90–3.10	2.87–3.14	2.81–3.22	1/13.4
4.0	3.95–4.05	3.94–4.07	3.91–4.10	3.88–4.13	3.82–4.20	3.76–4.28	3.66–4.42	1/18.4
6.0	5.89–6.11	5.85–6.16	5.79–6.23	5.71–6.32	5.59–6.48	5.45–6.68	5.24–7.04	1/28.4
12.0	11.6–12.5	11.4–12.7	11.1–13.0	10.9–13.4	10.4–14.2	9.9–15.2	9.2–17.4	1/58.4
∞	300– ∞	215– ∞	150– ∞	109– ∞	75– ∞	55– ∞	38– ∞	1/ ∞

DEPTH-OF-FIELD TABLES – continued

(ft)

Focused distance	Depth of field							Reproduction ratio
	f/4	f/5.6	f/8	f/11	f/16	f/22	f/32	
2.3	2'4"– 2'4-1/16"	2'4"– 2'4-1/16"	2'4"– 2'4-1/8"	2'4"– 2'4-1/8"	2'3-15/16"– 2'4-1/8"	2'3-7/8"– 2'4-3/16"	2'3-13/16"– 2'4-1/4"	1/2
2.5	2'5-15/16"– 2'6"	2'5-15/16"– 2'6"	2'5-7/8"– 2'6-1/16"	2'5-7/8"– 2'6-1/16"	2'5-13/16"– 2'6-1/8"	2'5-13/16"– 2'6-1/8"	2'5-11/16"– 2'6-1/4"	1/2.3
3.0	2'11-15/16"– 3'	2'11-7/8"– 3'1/16"	2'11-7/8"– 3'1/16"	2'11-13/16"– 3'1/8"	2'11-3/4"– 3'3/16"	2'11-11/16"– 3'1/4"	2'11-9/16"– 3'7/16"	1/3
4.0	3'11-7/8"– 4'1/16"	3'11-13/16"– 4'1/8"	3'11-3/4"– 4'3/16"	3'11-5/8"– 4'5/16"	3'11-1/2"– 4'7/16"	3'11-5/16"– 4'5/8"	3'11-1/16"– 4'15/16"	1/4.5
5.0	4'11-3/4"– 5'3/16"	4'11-11/16"– 5'1/4"	4'11-9/16"– 5'3/8"	4'11-3/8"– 5'9/16"	4'11-1/8"– 5'13/16"	4'10-7/8"– 5'1-1/8"	4'10-3/8"– 5'1-11/16"	1/6.1
6.0	5'11-5/8"– 6'5/16"	5'11-1/2"– 6'7/16"	5'11-5/16"– 6'5/8"	5'11-1/8"– 6'7/8"	5'10-11/16"– 6'1-5/16"	5'10-1/4"– 6'1-13/16"	5'9-1/2"– 6'2-11/16"	1/7.6
8.0	7'11-3/8"– 8'5/8"	7'11-1/8"– 8'7/8"	7'10-3/4"– 8'1-1/4"	7'10-5/16"– 8'1-11/16"	7'9-9/16"– 8'2-9/16"	7'8-11/16"– 8'3-9/16"	7'7-5/16"– 8'5-1/4"	1/10.6
12.0	11'10"– 12'1"	11'9"– 12'2"	11'9"– 12'3"	11'7"– 12'4"	11'6"– 12'6"	11'4"– 12'8"	11'– 13'1"	1/16.7
20.0	19'7"– 20'4"	19'5"– 20'6"	19'3"– 20'9"	19'– 21"	18'7"– 21'7"	18'1"– 22'3"	17'5"– 23'6"	1/28.9
50.0	47'7"– 52'6"	46'9"– 53'8"	45'6"– 55'5"	44'– 57'9"	41'9"– 62'3"	39'5"– 68'7"	36'– 82'10"	1/74.6
∞	985'– ∞	704'– ∞	493'– ∞	359'– ∞	247'– ∞	180'– ∞	124'– ∞	1/∞

FEATURES/SPECIFICATIONS

Focal length: 200mm

Maximum aperture: f/4

Lens construction: 9 elements in 6 groups

Picture angle: 12°20'

Distance scale: Graduated in meters and feet from 0.71m (2.34 ft) to infinity (∞)

Aperture scale: f/4 ~ f/32

Diaphragm: Fully automatic

Reproduction ratios: Scales provided 1:10 ~ 1:2 (for lens only), down to 1:1 (when using the Nikon Teleconverter TC-301)

Exposure measurement: Via full-aperture method coupling ridge provided for AI cameras and meter coupling shoe for non-AI cameras

Focusing system: Nikon Internal Focusing (IF) system

Lens hood: Slip-out type built into front of lens

Tripod mounting: Detachable tripod mount

Attachment size: 52mm (P = 0.75mm)

Dimensions: Approx. 66mm dia. × 172mm extension from the camera's lens mounting flange; overall length is approx. 180mm

Weight: Approx. 800g

Accessories: Front lens cap, rear lens cap LF-1, Teleconverter TC-301, Teleconverter TC-14A, Teleconverter TC-14B, 52mm screw-in filters, hard lens case CL-36

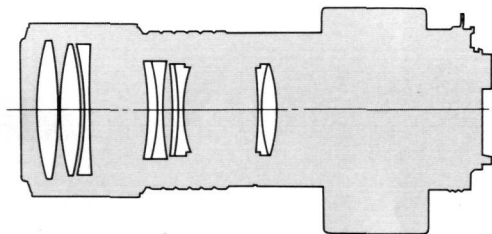

No reproduction in any form of this manual, in whole or in part (except for brief quotation in critical articles or reviews), may be made without written authorization from NIKON CORPORATION.

Nikon

NIKON CORPORATION

FUJI BLDG., 2-3, MARUNOUCHI 3-CHOME, CHIYODA-KU, TOKYO 100, JAPAN

PHONE: 81-3-3214-5311 **TELEX:** NIKON J22601 **FAX:** 81-3-3201-5856

Printed in Japan 9&071-A08(S211)